

 ZEBRONICS

Soundbar
MB JUKE BAR
NE 2550



User Manual

www.zebronics.com

Important Safety Instruction:

Dear Customer,

Thank you for purchasing the **ZEB-JUKE BAR 2550** Soundbar. Please read this user manual carefully and keep for future reference.

Warning

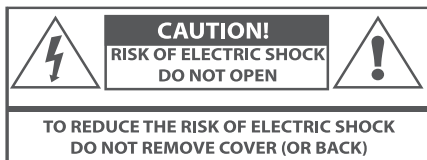

Caution:

- To reduce the risk of electric shock, do not dismantle the product and do not expose the device to rain or moisture. No user-serviceable parts inside.
- Refer servicing to qualified personnel only.



The lightning flash within an equilateral triangle is intended to alert you to the presence of uninsulated dangerous voltage within the product's enclosure that may be of sufficient magnitude to constitute an electric shock to a person or persons.



Important! This symbol alerts you to read and observe important warnings and instructions on the unit or in this manual.

Notice:

This appliance is not intended for use by persons (including children) with reduced physical sensory or mental capabilities, or lack of experience and knowledge, unless they have been given supervision or instruction concerning use of the appliance by a person responsible for their safety.

Children should be supervised to ensure that they do not play with the appliance.

- To prevent possible hearing damage, do not listen at high volume levels for long time periods or a sudden high volume level.
- Never use the device unsupervised! Switch off the device whenever you are not using it, even if not using it only for a short while.
- The appliance is not intended to be operated by means of external timer or separate remote control system.



- If the supply cord is damaged, it must be replaced by the manufacturer, its service agent or similarly qualified persons in order to avoid a hazard.
- Before operating this system, check the voltage of this system to see if it is identical to the voltage of your local power supply.
- The unit should not be impeded by covering the ventilation opening with items such as newspaper, table-cloths, curtains etc. Make sure that there are at least 20 cm of space above and at least 5 cm of space on each side of the unit.
- The device must not be exposed to dripping or splashing liquid, no objects filled with liquids such as vases, should be placed on the apparatus.
- To prevent fire or shock hazard, do not expose this equipment to direct heat, rain, moisture or dust.
- Do not position this unit near any water sources e.g. taps, bathtubs, washing machines or swimming pools. Ensure that you place the unit on a dry, stable surface.
- Do not place this unit close to a strong magnetic field.
- Do not place the unit on a amplifier or receiver.

- Do not place this unit in a damp area as the moisture will affect the life of electric components.
- Do not attempt to clean the soundbar with chemical solvents as this might damage the finish. Wipe with a clean, dry or slightly damp cloth.
- When removing the power plug from the wall outlet, always pull directly on the plug, never pull on the cord.
- Depending on the electromagnetic waves used by a television broadcast, if a TV is turned on near this unit while it is also on, lines might appear on the LED TV. Neither this unit nor the TV is malfunctioning. If you see such lines, keep this unit well away from the TV set.
- The mains plug is used to disconnect the device, the disconnected device should remain readily operable.

Important Safety Instructions

1. Read these instructions. Keep these instructions. Follow all instructions. Heed all warnings.
2. Do not use this apparatus near water.
3. Clean only with dry cloth.
4. Do not block any ventilation openings. Install in accordance with the manufacturer's instructions.

5. Do not install near any heat sources such as radiators, heaters, stoves, or other apparatus (including amplifiers) that produce heat.
6. Do not damage the power cord by walking over it or pinching it, particularly at plugs, convenience receptacles or at the point where they exit from the apparatus.
7. Only use attachments/accessories specified by the manufacturer.
8. Unplug this apparatus during lightning storms or when unused for long periods of time.
9. Refer all servicing to qualified service personal. Servicing is required when the apparatus has been damage in any way, for example, when the power-supply cord or plug is damaged, liquid has been spilled or objects have fallen into the apparatus, the apparatus has been exposed to rain or moisture, does not Poperate normally, or has been dropped.
10. The AC plug is used to disconnect the device, the disconnected device should remain readily operable. In order to disconnect the apparatus from the AC power completely, the AC plug must be removed from the AC outlet completely.

Important Notes

- This sound bar was especially developed for LED/LCD/Plasma TV's: It should not be used in combination with CRT TV's (Cathode Ray Tube TV's) in order to avoid image interference.
- Safety and operating instruction manual should be retained for future reference.
- The apparatus should not be exposed to dripping, splashing or placed in a humid atmosphere such as a bathroom.
- Do not install the product in the following areas:
 - Places exposed to direct sunlight or close to radiators.
 - On top of other stereo equipment that radiate too much heat-Blocking ventilation or in a dusty area.
 - Areas where there is constant vibration.
 - Humid or moist places.
 - Do not place near candles or other flames.
- Operate the product only as instructed in this manual.
- Before turning on the power for the first time, make sure the sound bar is plugged to power outlet.
- For safety reasons, do not remove any covers or attempt to gain access to the inside of the product. Refer any servicing to qualified personnel.

- Do not attempt to remove any screws, or open the casing of the unit; there are no user serviceable parts inside. Refer all servicing to qualified service personnel.

Unpacking and Set Up:

- Remove the Sound bar from the carton and remove all packing material from the Sound bar. Save the packing material, if possible, in case the Sound bar ever needs to be serviced or transported.
- The original carton and packing material is the only safe way to pack your Sound bar to protect it from damage in transit.
- Remove any descriptive labels or stickers on the front or top of the cabinet. Do not remove any labels or stickers from the back or bottom of the cabinet.
- Place your Sound bar on a level surface such as a table, desk or shelf, convenient to an AC power socket, out of direct sunlight, and away from sources of excess heat, dirt, dust, moisture, humidity or vibration.
- Unwind the Line cord connecting the AC adapter and extend it to its full length.

Protect Your Furniture

This model is equipped with non-skid rubber 'feet' to prevent the product from moving when you operate the controls. These 'feet' are made from non-migrating rubber material specially

formulated to avoid leaving any marks or stains on your furniture. However certain types of oil based furniture polishes, wood preservatives, or cleaning sprays may cause the rubber 'feet' to soften, and leave marks or a rubber residue on the furniture. To prevent any damage to your furniture we strongly recommend that you purchase small self-adhesive felt pads, available at hardware stores and home improvement center everywhere, and apply these pads to the bottom of the rubber 'feet' before you place the unit.

Power Source:

This sound bar is designed to operate with DC 24V, 1.25A

Product Representation:

SOUNDBAR

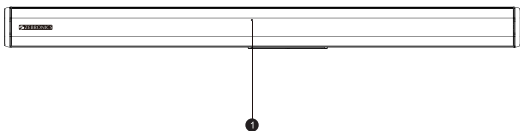

BACK VIEW

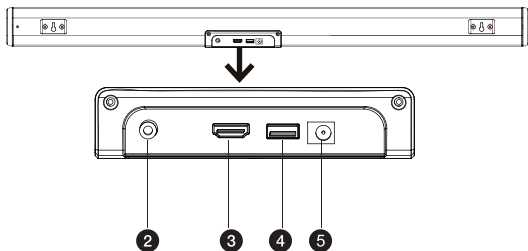

SIDE VIEW

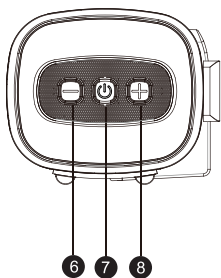

1. LED Indicator
2. AUX
3. TV(ARC)
4. USB
5. DC IN
6. VOL-
7. Standby Mode for power On/Off
8. VOL+

Remote Control:

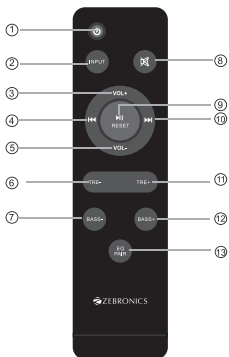

1. Power ON/OFF
2. Input Mode(AUX | USB | TV(ARC) | BT)
3. Volume increase
4. Previous Track
5. Volume Decrease
6. Treble Volume Decrease
7. Bass Decrease
8. Mute Button
9. Play / Pause | Reset Button
Short press: Play or pause the current track
Long press: Press and hold for more than 2 seconds to reset all functions to factory default.
10. Next Track
11. Treble volume increase

12. Bass Increase

13. EQ/ Pair

Short press: Mode to EQ, (Music/Movies/News)

Long press: Press and hold for more than 2 seconds to disconnect the paired BT device and reconnect the last disconnected BT device.

Positioning the Sound Bar

Place on a flat Surface:

Place the sound bar horizontally on a flat surface such as a TV unit or shelves and align it centrally with the TV screen. Allow some space between the speaker and the wall. Don't place inside a cabinet or on a walled shelf. Follow this steps for best sound output and good airflow around the sound bar.

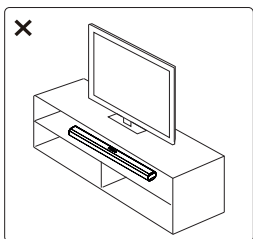
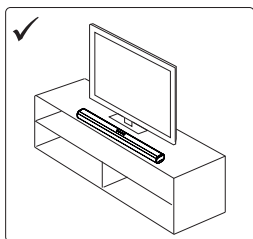
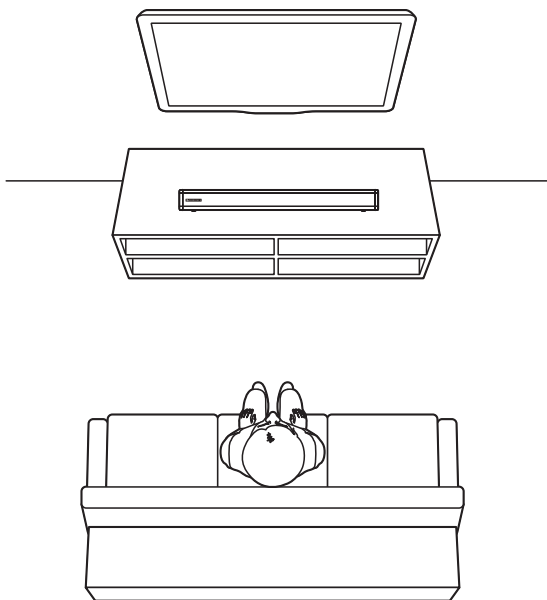

Table Placement

- Place the soundbar horizontally on a solid surface, such as a TV unit or shelves or computer table and align it centrally with the TV or computer screen.
- For best sound output and good airflow around the soundbar, place your soundbar as shown in the image



Mount on the wall:

WARNING : If you don't feel confident to correctly and securely wall-mount the sound bar, Seek the assistance of an experienced person or professional. Install the speaker on a vertical, fast, reinforced area of wall. For plaster walls, it is recommended to screw into wall studs for greater security. For optimum performance, allow at least 25mm/1" distance between the sound bar and the TV.

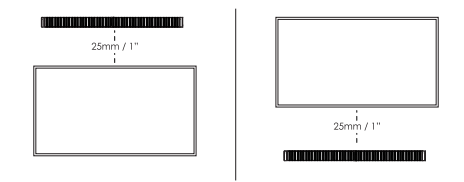

Follow below steps to mount the soundbar on the wall

1. Paste 2 pieces of EVA foam (with holes) on the two wall brackets aligning at the hole position of wall brackets.
2. Remove 4 screws from the rear housing of sound bar, then insert the 4 screws over the wall bracket screw holes aligning (on the side of EVA foam pasted), and then fasten the screws again.

3. According to the two hanging wall positions on the rear of sound bar, calibrate and mark the two hanging brackets hole position on the wall. Then drill two holes on the wall, firstly insert two expansion plastic screws on the wall, then fasten the hanging screws into expansion screw holes.
4. Then Paste the 2 pieces of EVA foam (without holes) on the two wall brackets downward. Then place the hollow cross in the centre of the bracket against the screws on the wall and hang the sound bar on the wall finally.

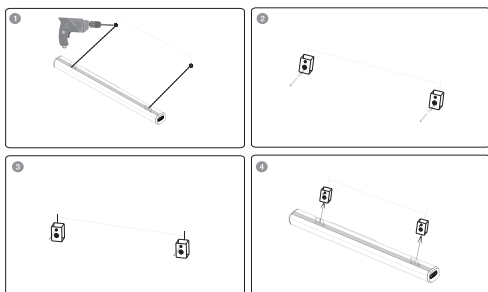

Operate Instructions :

Setting The Sound bar :

1. Plug in the power cord and the LED will light up
2. Switch on the sound bar by pressing "STANDBY" button on sound bar or on remote controller. After switching on, the default input mode will appear on display.
3. Input modes can be changed by pressing the "INPUT" button on remote controller.

The indicator can change to different colors, representing different states:

Blue = BT Mode

Cyan = TV(ARC) Mode

Green= AUX Mode

Pink = USB Mode

Power ON and OFF

1. Plug the power cord of sound bar into a wall outlet, it will automatically enter standby mode.
2. Short-press the "STANDBY" button on sound bar
3. To turn off, press and hold the "STANDBY" button for 2 seconds, then unplug from wall outlet.

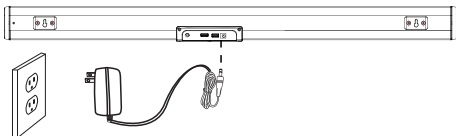

Playing Audio via BT Connection :

1. Use either the buttons on the Sound Bar or the "Input" button on the remote to activate BT mode. A Blue LED indicator will indicate that BT mode has been selected.
2. Activate the pairing function on your phone or other compatible device and select "**ZEB - JukeBar 2550**".
3. When successfully paired, you will hear a tone and the LED will stay on.
4. The remote control includes BT mode playback controls.

Notes: *If your Pairing device Switched off or Manual disconnected, the sound bar will automatically enter pairing mode. If the connected device is switched off or manual disconnected, the sound bar will automatically enter pairing mode. Once successfully connected, the device will be re-established once you re-enter wireless range (10 meters). To connect to other devices, repeat the above pairing steps.*

Audio Input (AUX) Connection:

1. Firstly connect the soundbar to your PC, laptop, smart-phone, TV, or other audio devices by using an AUX cable provided. Make sure that these devices have both AUX IN and AUX OUT terminals.
2. Use either the buttons on the soundbar or the "input" button on the remote to activate AUX mode. A green LED indicator will indicate that the AUX mode has been selected
3. Playback function (Play / Pause, tracks, pair) cannot be adjusted through the soundbar remote when in AUX mode

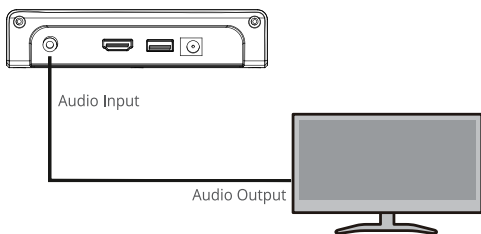

Note: *For some computers, you may need to access the audio control panel to manually set the sound bar as above picture.*

Playing Audio via USB Port:

When the USB flash drive is plugged in, the sound bar automatically switches to USB input mode. A Pink LED indicator will indicate that USB mode has been selected. This mode cannot be selected on the sound bar or remote control unless it is connected to a USB flash drive.

1. Ensure that your USB flash drive contains MP3 audio files (other file types not supported).
2. The remote control includes USB input mode playback controls.

TV(ARC) Mode

- The sound bar supports TV(ARC) with audio return channel (ARC). You can hear the TV audio through your sound bar by using a single TV(ARC) cable. But on condition that your TV is ARC compliant.
- Using a high speed TV(ARC) cable, connect the TV(ARC) connector on the sound bar to the TV(ARC) connector on the TV. The TV(ARC) connector on the TV might be labeled differently. For details, see the user manual of your TV.
- When TV(ARC) is connected, TV sound setting in "sound output" mode should be set as <external PCM Stereo>, in addition, digital audio output mode should be set as

<automatic> or <decoded output as PCM state>. When the TV(ARC) cable is connected, the TV digital audio output is set as PCM format. Then start playing music on the TV.

- Press "INPUT" button on the remote control or "STANDBY" button on sound bar to select TV(ARC) mode and the LED mode indicator will turn on Cyan. Different TV might be different setting, please refer to your TV User Manual.
- Use the volume buttons to adjust the volume to your requirements.
- You can also change the audio settings by using the relevant buttons on the remote control.

Note:

1. When connecting a device such as a TV/Set-top box/DVD/ game console with TV(ARC) cable, set the audio output mode of the device to PCM mode <digital TV (ARC) output>.
2. The TV is connected to a TV(ARC) port with sound bar. Different TVs might have different setup menus, but the operation approach is the same.
3. If needs to connect set-up box meanwhile, please firstly connect the TV(ARC) connector and paired to the sound bar. Then connect the set-top box.

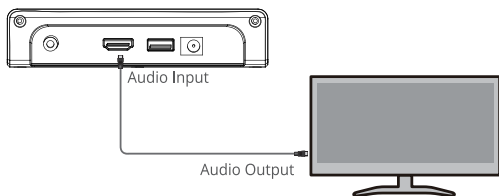

Features:

- 2.0 Channel Soundbar
- 80W RMS output
- Powerful Dual Drivers
- Multi Connectivity (BT v5.4 | TV (ARC) | USB | AUX)
- Remote control
- Wall Mountable
- LED Indicator

Specifications:

Output Power (RMS)	: 80W
Driver Size	: (5.8 x 9.8 cm) x 2
Impedance	: 8Ω
Frequency Response	: 70Hz-20kHz
S/N Ratio	: ≥66dB
Separation	: ≥33dB
File format support	: MP3

Line Input	: 3.5mm & TV (ARC)
Max supported memory size (USB)	: 32GB
BT name	: ZEB-JukeBar 2550
BT version	: v5.4
Product Dimensions	: 86 x 8 x 6.8 cm (W x D x H)
Net.Weight	: 1.5 kg

Package Contents:

Sound Bar	: 1 U
Remote Control	: 1 U
Power Adapter	: 1 U
Input Cable	: 1 U
Wall Mount Fasteners	: 1 U
QR Code Guide	: 1 U

TROUBLESHOOTING

PROBLEM/TROUBLE	POSSIBLE CAUSE	SOLUTION
There is no sound output from soundbar.	Another input source is selected.	Select an appropriate input source.
	The mute function is activated.	Cancel the mute function.
	The volume of soundbar or TV/other device is adjusted too low.	Increase the volume level on soundbar or by remote control or on TV.
	The power cable of the unit is not connected properly.	Make sure that the power cable of the unit is connected to an AC wall outlet securely.
	Input jacks on a playback device are connected.	Connect the input jack on the soundbar and the output jack on the playback device.
	Signals that the soundbar cannot playback when being input.	When soundbar and TV or other devices are connected by an audio cable through HDMI eARC port output, Select the correct audio input and output. Make sure the digital audio output setting on the playback device to PCM format. Since the output format of our soundbar is PCM, if it is used, the decoding format of TV or other devices will be adjusted to PCM state.
The sound is distorted or echoed.	TV volume is not muted.	If you play audio from TV through the soundbar, make sure that the TV is muted.
The volume decreases when the unit is turned on.	The automatic volume adjustment function is activated. To prevent excessive loudness, the unit automatically controls its volume within a certain level when the unit is turned on.	Turn up the volume as required.
Noise is heard.	The soundbar is too close to another digital or high-frequency device.	Move those devices away from the sound bar.

PROBLEM/TROUBLE	POSSIBLE CAUSE	SOLUTION
The unit cannot be operated by using the remote control.	The unit is out of the operating range.	Use the remote control within the operating range.
	The batteries are weak.	Replace with new batteries.
	The remote control sensor of the soundbar is exposed to direct sunlight or strong lighting.	Adjust the lighting angle or reposition the soundbar. Make sure our product cannot be used in sunlight.
The TV cannot be operated by using the TV's remote control.	The unit is blocking the TV's remote control sensor.	Position the unit so that it does not obstruct the TV's remote control sensor.
A device cannot connect the soundbar or the unit cannot be connected to a Bluetooth device.	Bluetooth function of the device is not activated, not paired or connected correctly.	Restart the soundbar and try pairing again. You have not enabled the Bluetooth function of the device; see the user manual of the device on how to enable the function and correctly connected the device. The sound bar is already connected with another Bluetooth device. Disconnect the connected device, and then try again.
	Bluetooth is not selected as the input source.	Select Bluetooth as the input source.
	The unit is connected to a different Bluetooth device.	Un-pair the Bluetooth device that is currently connected and pair with the desired Bluetooth device.
	The unit is too far away from the Bluetooth device.	Move the Bluetooth device closer to this unit.
	A device emitting electromagnetic waves (such as a microwave oven, a wireless device and so on) may be placed nearby.	Do not use this unit near devices that emit electromagnetic waves.
	The Bluetooth device that you are using may not support the protocol.	Use a Bluetooth device that supports the protocol.
Sound quality of audio play from a connected Bluetooth device is poor and connection is not stable.	The Bluetooth reception is poor.	Move the device closer to the sound bar or remove obstacles between them.
	No sound can be heard or sound breaks (Bluetooth mode)	
No sound can be heard or sound breaks (Bluetooth mode)	The volume on the Bluetooth device may be too low.	Raise the volume on the Bluetooth device.
	Bluetooth is not selected as the input source.	Select the Bluetooth as the input source.
	Playback on the device has not been performed.	Perform playback on the device.
	The sound output on the Bluetooth device may not be set to this unit.	Select this unit as the output device on the Bluetooth device.
	The connection to the Bluetooth device was cut off.	Connect with the Bluetooth device one more time.
	The unit may be too far away from the Bluetooth device.	Move the Bluetooth device near this unit.
A device emitting electromagnetic waves (such as a microwave oven, a wireless device and so on) may be placed nearby.	Do not use this unit near device that emit electromagnetic waves.	
There is no sound from soundbar - TV(eARC) Mode	Incorrect HDMI cable is used causing no signal to be sent to soundbar. Incorrect input mode is selected.	1. Make sure that the user connected TV and sound bar by a 19-core HDMI cable. 2. The soundbar and TV are connected through TV(eARC) port output; make sure that the TV is HDMI eARC or HDMI ARC compliant. 3. Set the TV to HDMI eARC or HDMI ARC (CEC). Set the audio output mode of TV to PCM format. (Or refer to your TV user manual)
There is no sound from bar (OPTICAL Mode)	OPTICAL cable might be damaged and no signal is received by the soundbar due to a failed connection and incorrect operation mode selected.	1. Replace the OPTICAL cable with a new one to connect. 2. Set your TV audio output to PCM format. (Pls refer to your TV user manual)
There is no sound from sound bar (USB mode)	USB file type is not support & Soundbar doesn't switch to USB input mode automatically when USB is inserted.	Make sure that USB flash drive contains MP3, ALAC, FLAC files because other file types are not supported. Switch the input mode once again, then playback again.

ISO 9001:2015 Certified Company
www.zebronics.com