



Gamer's Dream



ZEB Gaming Chair
GC1600

User Manual

www.zebronics.com

Thank you for purchasing **ZEB-GC1600** premium gaming chair. Please read this user manual carefully before operation & save it for future reference.

To know more about Terms and conditions for warranty policy, please visit :













<https://zebrionics.com/pages/warranty-policy>

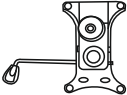

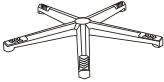
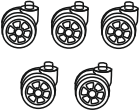
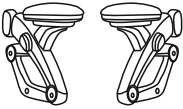
Specification

Chair Cover Material	: PVC
Frame Type	: Metal Frame
Foam Density	: 30 kg/m ³
Legs Material	: Nylon Base
Swivels angles	: 360°
Adjustable Tilt Angle	: 90° - 125° Backrest Angle
Armrest type	: Recliner Armrests
Caster Wheels size	: 6 cm
Gas Lift Class	: Class 3
Product Dimension (W x D x H)	: 59 x 52 x 129 cm*
Net Weight	: 14kg

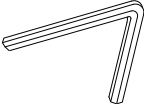
*at maximum height.

Package Contents:

① 	② 
③ 	④ 
⑤ 	⑥ 
⑦ 	⑧ 
⑨ 	⑩ 
⑪ 	⑫ 
⑬ 	⑭  Nx2

<p>⑮ Px4</p>  <p>M6 x 20mm</p>	<p>⑯ Ox2</p>  <p>M8 x 40mm</p>
<p>⑰ Qx6</p>  <p>M8 x 30mm</p>	

Installation Procedure:

Step 1: Setting up the Base

- Install the castor wheels to the Base.
- Install the Gas lift to the Base.
- Now place the Plastic cover on the top of the gas lift.

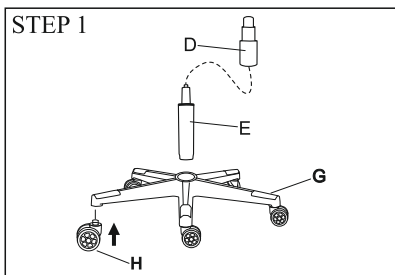

Step 2: Connecting the Lift mechanism

- Align the Gas lift mechanism to the Armrest mounting points of the seat cushion.

- Place the included screws(M6 x 20mm) to the mount on the Gas Lift mechanism to the Seat Cushion.

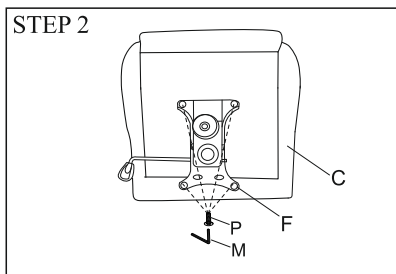

- By using the provided Allen Key, Fasten the included screws into the mounting points of the Seat Cushion as shown in the reference image.

Step 3: Combining the Seat Cushion

- Align the seat cushion to the centre of the Gas cylinder.
- Join the Gas Lift Mechanism and the gas cylinder by placing the seat cushion on the top of the gas lift cylinder

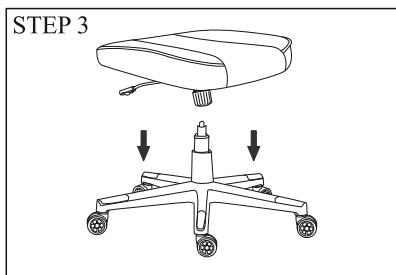

Step 4: Joining the Armrests

- Align the Armrests (1.Left, 2.Right). to the respective mounting points which is present on the sides of the Seat cushion.
- Place the included screws (M8 x 30mm) to the mounting points of the Armrests.
- Using the included Allen key, Fasten the included screws to the mounting points of the seat cushion as displayed in the reference image.

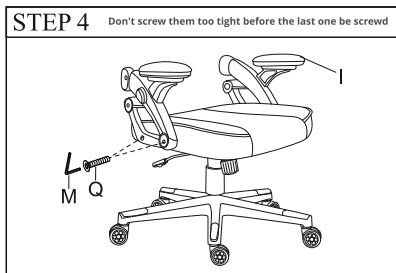

Caution:- Avoid fastening The Screws too tight Before the last screw is mounted.

Step 5: Linking the Included Backrest cushion

- Align the Backrest cushion to the respective mounting points of the Armrests (1.Left, 2.Right).
- Place the included washer along with (M8 x 30mm) screws.

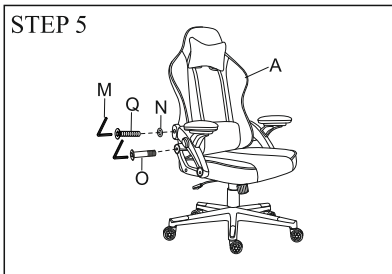

- Place the included washer along with (M8 x 40mm) screws.
- Using the included Allen key, Fasten the included screws to the mounting points of the seat cushion as displayed in the reference image.

Step 6 : Placing the Armrest Placements

- Place the Armrests fitments (1.Left, 2.Right) to the respective sides of the armrest.
- Place the Included screw caps tot respective slots as shown in the product image

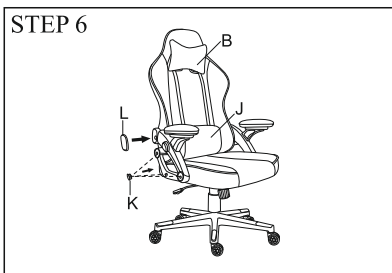

Step 7: Finishing Up

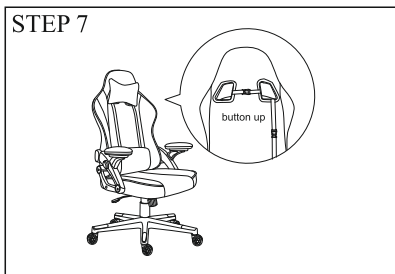

- Place the Headrest cushion and Lumbar cushion. That concludes the assembly process of the gaming chair.

Step 8: Final outcome





ISO 9001:2015 Certified Company
www.zebronics.com